

REV.	ECO NO.	DATE	SIGN	DESCRIPTION
A		2007.07.01	黄派通	NEW DRAWING

NOTES:

- MATERIAL:
HOUSING:THERMOPLASTIC(UL94-V0)
ACTUATOR:THERMOPLASTIC(UL94-V0)
TERMINAL:PHOSPHOR BRONZE MATTE TIN PLATED
LEG :BRASS MATTE TIN PLATED
- "▼"IMPORTANT DIMENSION
- PART NO.

NO. OF PIN	DIMENSION			
	A	B	C	D
4	8.00	6.80	1.50	2.58
5	8.50	7.30	2.00	3.08
6	9.00	7.80	2.50	3.58
7	9.50	8.30	3.00	4.08
8	10.00	8.80	3.50	4.58
9	10.50	9.30	4.00	5.08
10	11.00	9.80	4.50	5.58
11	11.50	10.30	5.00	6.08
12	12.00	10.80	5.50	6.58
13	12.50	11.30	6.00	7.08
14	13.00	11.80	6.50	7.58
15	13.50	12.30	7.00	8.08
16	14.00	12.80	7.50	8.58
17	14.50	13.30	8.00	9.08
18	15.00	13.80	8.50	9.58
19	15.50	14.30	9.00	10.08
20	16.00	14.80	9.50	10.58
21	16.50	15.30	10.00	11.08
22	17.00	15.80	10.50	11.58
23	17.50	16.30	11.00	12.08
24	18.00	16.80	11.50	12.58
25	18.50	17.30	12.00	13.08
26	19.00	17.80	12.50	13.58
27	19.50	18.30	13.00	14.08
28	20.00	18.80	13.50	14.58
29	20.50	19.30	14.00	15.08
30	21.00	19.80	14.50	15.58
31	21.50	20.30	15.00	16.08
32	22.00	20.80	15.50	16.58
33	22.50	21.30	16.00	17.08
34	23.00	21.80	16.50	17.58
35	23.50	22.30	17.00	18.08
36	24.00	22.80	17.50	18.58
37	24.50	23.30	18.00	19.08
38	25.00	23.80	18.50	19.58
39	25.50	24.30	19.00	20.08
40	26.00	24.80	19.50	20.58
41	26.50	25.30	20.00	21.08
42	27.00	25.80	20.50	21.58
43	27.50	26.30	21.00	22.08
44	28.00	26.80	21.50	22.58
45	28.50	27.30	22.00	23.08
46	29.00	27.80	22.50	23.58
47	29.50	28.30	23.00	24.08
48	30.00	28.80	23.50	24.58
49	30.50	29.30	24.00	25.08
50	31.00	29.80	24.50	25.58
51	31.50	30.30	25.00	26.08
52	32.00	30.80	25.50	26.58
53	32.50	31.30	26.00	27.08
54	33.00	31.80	26.50	27.58
55	33.50	32.30	27.00	28.08
56	34.00	32.80	27.50	28.58
57	34.50	33.30	28.00	29.08
58	35.00	33.80	28.50	29.58
59	35.50	34.30	29.00	30.08
60	36.00	34.80	29.50	30.58

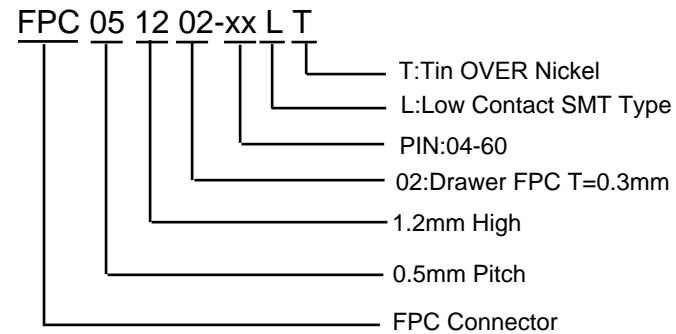
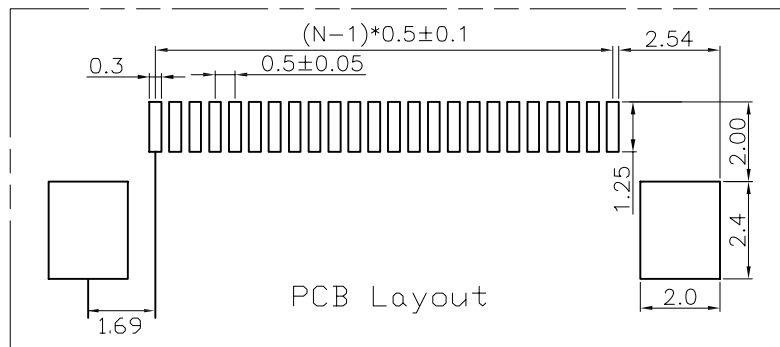
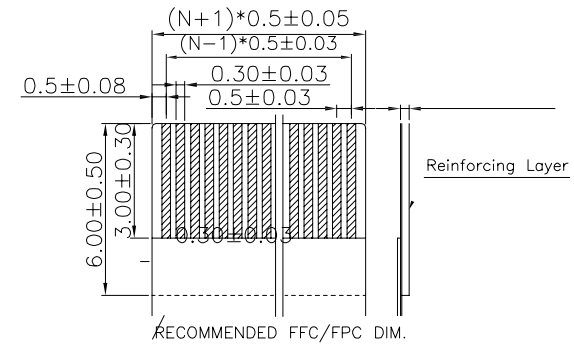
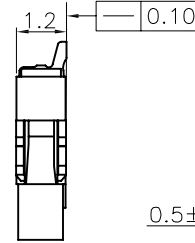
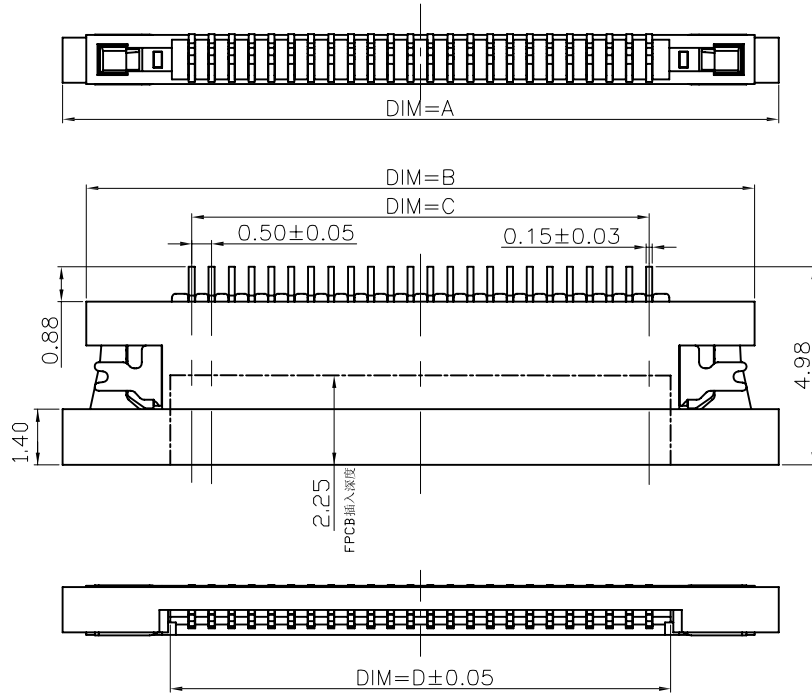

TOLERANCE UNLESS SPECIFIED	
LINEAR	ANGLE
.X ±0.25	X° ±5°
.XX ±0.15	.X° ±2°
.XXX ±0.10	.XX° ±--

DATE 2007.07.01
SCALE 1/1
UNIT mm

DAR. BY
CHK. BY
APP. BY

MATERIAL
FINISH
PART NO.

深圳市联泽瑞科技有限公司
SHENZHEN LIANZERUI TECHNOLOGY CO., LTD.



TITLE: FPC 0.5P 1.2H 抽屉式下接
DWG NO. FPC051202-xxLT

REV. A